



Since 1979

# POLYETHYLENE (PE) WATER TANK

Chin Lean PE Water Tank are designed for efficiency and quick installation. Polyethylene tank are seamless, water tight, chemical resistant and won't crack or rust.

## SQUARE series

SN50



SN100



SN200



SN70



SN150



SN250



### Warranty



### Certification



# POLYETHYLENE WATER TANK

## SQUARE series

### Features

- Certified by SIRIM QAS International Sdn. Bhd. with License No.: PC007118  
Standard reference: MS 1225-1 : 2014
- Application : Cold water storage for indoor and outdoor use.
- Material : Polyethylene (PE)

### Advantages

- # Easy maintenance
- # Cost effective
- # Non-Toxic
- # Fast and easy to install
- # Protection from corrosion
- # UV protected
- # Lightweight

### Dimension

MODEL	NOMINAL CAPACITY	EXTERNAL DIMENSION MM (INCH)			
		TOP (T) L X W	BOTTOM (B) L X W	HEIGHT (H1)	HEIGHT (H2)
SN 50	70 Gal	980 (39")	711 (28")	482 (19")	686 (27")
SN 70	100 Gal	1195 (47")	1040 (41")	410 (16")	508 (20")
SN 100	150 Gal	1270 (50")	965 (38")	635 (25")	737 (29")
SN 150	200 Gal	1473 (58")	1194 (47")	686 (27")	787 (31")
SN 200	250 Gal	1448 (57")	1168 (46")	686 (27")	889 (35")
SN 250	300 Gal	1448 (57")	1143 (45")	838 (33")	1041 (41")

(Capacity more than 600 Gal (Standard : MS 1225-1 : 2014))

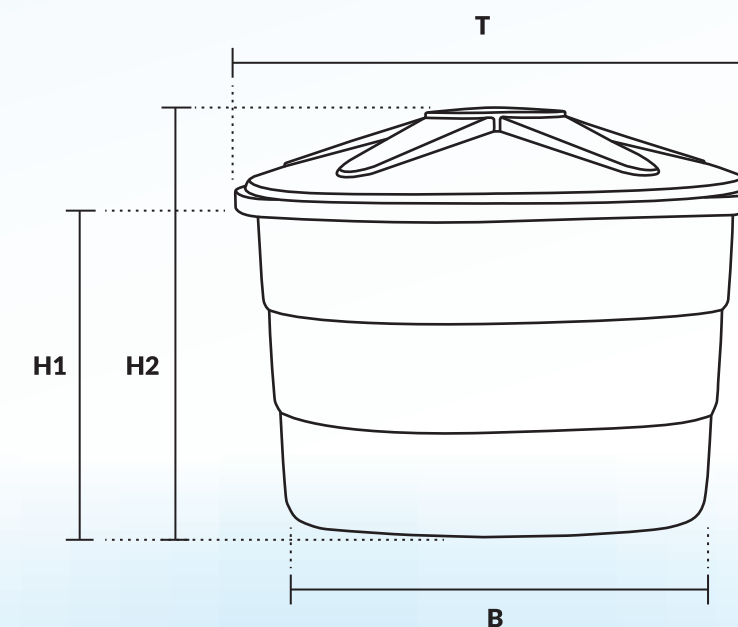

CHIN LEAN

**CHIN LEAN PLASTIC FACTORY SDN BHD**(049922-V)

Lot No. 5005, Jalan Chui Chak, 36700 Langkap, Perak, Malaysia

T +605-659 3444 (3 Lines) • F +605-659 3175

wasap.my/60195137473

chinlean49922@gmail.com / sales@chinlean.com

www.chinlean.com.my / www.chinlean.com

